

2020

MINDRUM LASERS

AgLaser Agricultural Aviation Laser Altimeter

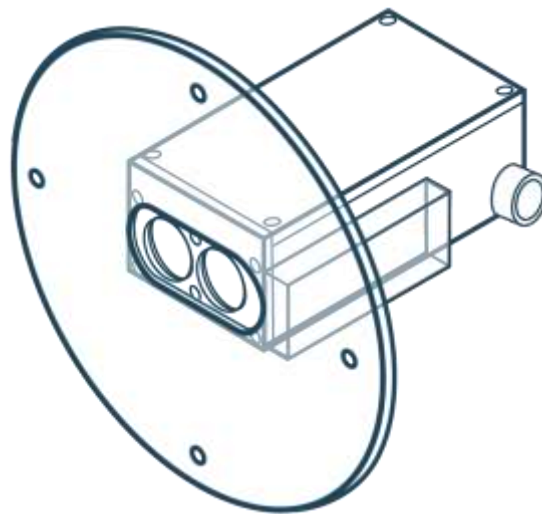

AgLaser User Manual

MINDRUM LASERS

AgLaser User Manual



© Mindrum Precision
10000 Fourth St
Rancho Cucamonga, CA 91737
Phone 909.989.0939

© Mindrum Precision 2020, all rights reserved. This manual and the equipment referred to herein are copyright held works of Mindrum Precision, Rancho Cucamonga, California, USA under license of Carlson Software, of Maysville Kentucky. Reproduction in whole or in part, including reverse engineering or utilization of machinery capable of reproduction or retrieval, without the express permission of Mindrum Precision is strictly prohibited. Information in this document is subject to change without notice.

Table of Contents

General Information	1
AgLaser customer service.....	1
Technical Specifications.....	2
Component List	3
Installation	4
Extension cable.....	4
Laser module	4
Display installation	5
Initial Setup	6
Powering on	6
Selecting a unit of measure.....	6
Setting target altitude	7
Setting altitude tolerance.....	7
Decimal point settings	7
Recalibrate for wheels-to-ground height	8
Adjust display brightness	9
In-Flight Operation	10
Pre-flight checklist.....	10
Altitude indicators.....	11
Error messages.....	11
Handling Instructions.....	12
Class 1 eye safety rating.....	12
General handling information	12
Cleaning.....	13
Supplemental type certificate	13
Warranty information.....	13

General Information

Get to know your AgLaser unit- the world's most accurate and reliable laser altimeter specifically designed for the Agricultural Aviation industry.

Congratulations on the purchase of your AgLaser laser altimeter system by Mindrum Lasers, the laser division of Mindrum Precision! Before installing your unit, please read through this manual, and make a note of your unit's serial number, which can be found on Laser Module itself or on the original packaging.

AgLaser customer service

Providing the highest quality customer service is extremely important to us, and whether you have a single unit or you have a fifty-plane fleet, we are here to answer any questions that you might have. If your instrument requires servicing at any time, please contact us at:

Mindrum Precision, attn Mindrum Lasers
10,000 Fourth Street
Rancho Cucamonga, CA 91730 USA
(909)989-0939
sales@mindrumlasers.com

Technical Specifications

The following information is from our standard ILM-150-R laser units, which are the active laser module in the AgLaser system. These specifications may vary on customized units.

Type.....	GaAs Laser Diode
Wavelength.....	905 nm
Passive Range.....	150 m
Accuracy.....	10 cm
Measurement Rate.....	9 Hz
Eye Safety.....	Class 1
Operating Temperature.....	-20°C to 60°C
Storage Temperature.....	-20°C to 90°C
Water Resistance Class.....	IP67
Construction.....	Black Anodized Aluminum
Dimensions.....	116 mm x 54 mm x 43 mm
Weight.....	320g

Information contained herein is believed to be accurate. Mindrum Precision assumes no responsibility, however, for its use. Technical information is subject to change without notice.

Section
2

Component List

Before you begin the installation process, make sure that all of the components for your AgLaser Unit are present and you have all of the tools needed to complete the job.

- 

Laser Module & Power Cable (1 each)
- 

Extension Cable with Grommet (1)
- 

Mounting Plate (1)
- 

Mounting Plate Gasket (1)
- 

Vega Display (Mounting screws not shown)
- 

Laser Housing Gasket (1)
- 

Socket Head Screw (2)
- 

Lock Washer (2)

In addition to the included components, you will also need a hand drill. Both a drill bit and a hex key are included for your convenience.

Installation

Installation for your AgLaser unit should be a relatively quick process, but please call us at any time if you have questions about this process.

Extension cable

REQUIRED TOOLS:
7/16" Metal bit,
Drill

1. First, remove the wing root cap.
2. Drill a 7/16" hole through the fuselage, approximately 12" back from the leading edge.
3. Affix the grommet in the through hole.
4. Route one end of the extension cable through the wing to the selected underwing inspection plate.
5. Route the other end of the extension cable into the cockpit.

Laser module

1. Place the Laser Gasket into the Mounting Plate.
2. Place the Laser Module into the Mounting Plate. Make sure the Laser Module is sitting flush against the Laser Gasket and the threaded holes on the Laser Module are lining up with the through holes on the Mounting Plate.

REQUIRED TOOLS:
4mm hex key

3. Secure the Laser Module onto the Mounting Plate using the Socket Screws and the Lock Washers.



4. Place the Mounting Plate Gasket on the Mounting Plate on the same side the Laser Module is secured. There are two sets of holes: one for an Air Tractor and one for a Thrush. Cessna models will come with a Cessna-specific Mounting Plate Gasket. Use the set that fits your specific aircraft type.

CAUTION:
Make sure the Laser Module will not interfere with control cables, wires, or structure inside the wing.

5. Remove the appropriate under-wing inspection plate. You will use the screws taken from this plate to re-attach the AgLaser unit.



6. Connect the Extension Cable to the Laser Module, firmly insert the male end to secure the connection.

7. Install the Mounting Plate in place of the inspection plate.

8. Secure with the removed inspection plate screws.

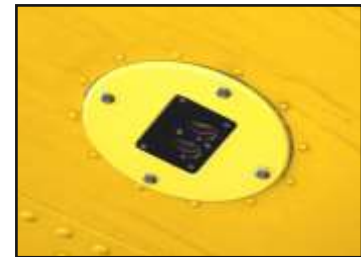

Display installation

The following instructions are for the Vega display stand-alone system. If you are using a different integration, please refer to that system's instructions for the next step, or contact us with any questions.

1. Mount the display to an open 2.25" spot in the dash using the 4 included bolts and nuts. (A template is included if a hole needs to be cut)
2. Connect the Power Cable to the Extension Cable, pushing the male end into the female end.
3. Connect the Power Cable to a 9V-28V DC power source. A 1A inline fuse is recommended to be installed.
4. Connect the Power Cable to the back of the display. Tighten the screws on the connector.

Initial Setup

The AgLaser system has multiple viewing options and integrations, including multiple GPS-enabled systems. If you would like more information on the different options available to you, please email us at sales@mindrumlasers.com, and we will let you know all of the options available.

Powering on



Home Screen

1. As soon as power is supplied, the start-up screen will display for approximately 5 seconds.
2. The screen will automatically change to the home screen and will begin displaying a range.

Selecting a unit of measure

The AgLaser is designed to provide accurate, reliable altitude data in either meters or feet. To select your desired unit of measure, follow the steps below.



Select units of measure

1. From the home screen press the dial twice to enter the Unit setup menu.
2. Rotate the dial until **ALTITUDE UNIT** is highlighted.
3. Press the dial, and then rotate the dial to select your preferred unit of measure
4. Press the dial to save the value, and then press F1 twice to exit to the Home Screen.

Setting target altitude

Your target altitude is the exact center of the altitude range that you are looking to fly in. As an example, if your parameters are from 40m to 60m, set your target altitude to 50m.



Select a target altitude

1. From the home screen, **rotate the dial** to adjust your desired target altitude, displayed in the top right corner of the screen.

Setting altitude tolerance

Once you have established your target altitude, you need to establish your altitude tolerance. This value determines the size of the altitude window that you can fly in without triggering an indication from your Vega display. To use our earlier example, if you want to maintain an altitude of 40m-60m, you would set your target altitude as 50m, and then use the steps below to adjust your altitude tolerance to +/- 10m.



Create your altitude range

1. From the home screen press the dial twice to enter the Unit setup menu.
2. Rotate the dial until **TOLERANCE** is highlighted.
3. Press the dial, and then rotate the dial to set the desired tolerance value. If needed, you can also press F2 to change between 1X and 10X precision to reach the exact value you need.
4. Press the dial to save the value, and then press F1 twice to exit to the Home Screen.

Decimal point settings

While this device is a precision measurement tool, we know that sometimes a more simplified view can be beneficial. For this reason pilots have the option of having the display show precise readouts to one tenth of your selected unit of measure (ft/m), or displaying your altitude rounded to the nearest whole unit. This is entirely a matter of preference, but for pilots who are looking down for a fraction of a second and want the information as plainly as possible, the decimal point can be removed.



Choose your display precision

1. From the Home Screen press the dial twice to enter the unit setup menu.
2. Rotate the dial until **DECIMAL PT** is highlighted.
3. Press the dial then rotate to select **ON** or **OFF**.
4. Once you have selected your desired option, press the dial a final time to save, followed by pressing F1 twice to return to the Home Screen.

Recalibrate for wheels-to-ground height

If left in the initial condition that an AgLaser unit is received in, the Vega display will give a precise measurement of the exact height of the laser module, wherever it has been installed in the plane. This means that left as-is and installed in the wing of a plane, the unit will give you a reading of your wing-to-ground height at any given time. Users also have the option to recalibrate this data to give precise wheels-to-ground height instead by zeroing out the initial value while the plane is on the ground using the process below.



Switch to wheels-to-ground height

1. From the Home Screen press the dial twice to enter the unit setup menu.
2. Rotate the dial until **ZERO ALT SENSOR** is highlighted.
3. Press the dial followed by F2 to zero out the sensor. The unit will indicate that this has been completed by displaying the word “Done” to inform the user that the recalibration process was successful.
4. Press DIAL to return to the Unit setup menu. Press F1 twice to exit to the Home Screen.
5. If you wish to calibrate to a custom height, contact Mindrum Lasers for further instructions.

Adjust display brightness



**Adjust brightness
to your preference**

1. From the Home Screen press the dial then rotate until the display reads **MISC SETUP**.
2. Press the dial to enter the **MISC SETUP** menu.
3. Press the dial to select **BACKLIGHT**.
4. Rotate the dial to select desired brightness. Once this has been completed, press the dial a final time to save and return to the MISC SETUP menu.
5. Press F1 twice to return to the home screen.

In-Flight Operation

Be sure to review this section in full before using the AgLaser system in any real-world application. It is important to note that while the AgLaser system is a precision instrument, it is in no way intended to be a replacement for good judgment and normal flying practices; as with any other instrumentation, pilots need to be aware of their surroundings and not depending solely on any one instrument at any time. That being said, the AgLaser system is an extremely powerful tool to give you a greater awareness of your positioning, and if used properly can help you maintain the exact height you need to produce optimal results.

Pre-flight checklist

Before use, be sure all desired steps in the Initial Setup section of this manual have been completed.



Initial reading should be zero for wheels-to-ground height

1. If you chose to calibrate your system to read wheels-to-ground height, **make sure the system has been calibrated and is reading zero before take-off.**
2. Make sure the desired altitude range has been entered into the system, using the **Setting Target Altitude** and **Setting Altitude Tolerance** instructions in the previous section.
3. Ensure all other settings (units of measure, system brightness, and decimal point settings) have been correctly selected per your preference.

Altitude indicators



Too High – Descend!



In Tolerance – Good!



Too Low – Pull Up!



**Outside of max range
for AgLaser unit**

1. While in flight, the system will display the current altitude in feet or meters (depending on your preference). This will be the largest number in the center of the screen.
2. **WARNING! The AgLaser is intended to work in conjunction with the aircraft's other instrumentation as well as the pilot's good judgement. Never rely solely on the system.**
3. If the altitude of the aircraft rises above the preset tolerance zone, the descent indicator (the triangle pointing upward over the altitude reading) will light up, signaling that the pilot should ascend. Remember that while your target altitude will be displayed in the top corner, your tolerance zone is set in the UNIT SETUP menu as described in the previous section.
4. If your altitude is within your target parameters, no red indicators will be lit, and the only colors on your display will be black or white.
5. If the altitude drops below the preset tolerance zone, the ascent indicator (red triangle above the altitude reading) will light up, signaling that the pilot needs to descend to be within the preset tolerance zone.

Error messages

1. If the aircraft rises outside the system capabilities, "OUT OF RANGE" will be displayed. The display will revert back to normal once the aircraft comes into range.
2. If the system permanently displays "OUT OF RANGE" or "COMM ERROR" even after re-calibration, the system may need servicing. Please contact Mindrum Precision for assistance.

Handling Instructions

Mindrum Lasers is proud to produce the most reliable and rugged time-of-flight laser systems on the market, but like all other systems they do require proper care and handling for extended life and optimized performance.

Class 1 eye safety rating



The Laser Module is classified as a Class 1 eye safe laser product in compliance with the European eye safety regulation CENELEC EN60825-1. Nonetheless, we recommend that the system be turned off while cleaning the lenses and that no one ever look directly into the Laser Module.

WARNING! Never open the Laser Module's protective housing as this may result in exposure to Class 3B Radiation. Do not operate the system if the Laser Module is damaged. Mindrum Lasers and Mindrum Precision assume no responsibility for improper handling.

General handling information

The Laser Module is comprised of sensitive optical, electronic and mechanical components. Never apply force or shock to the lenses or to the housing of the instrument. As with other optical instruments, the Laser Module should be protected from being shaken, knocked or dropped.

Cleaning

The Laser Module lenses should be gently cleaned when necessary using a suitable lens cleaning fluid such as ethylene alcohol and a suitable cleaning device such as a Q-Tip. While exposure to moisture or water is not a problem with the IP 67 rating, do not use a pressure washer on these units, as this can lead to damage or destruction that is not covered by the warranty.

Supplemental type certificate

No supplemental type certificate (STC) is available for the AgLaser. Thus, it is the responsibility of the owner to report this aircraft alteration. Per FAA § 21.93, a “minor change” is one that has no appreciable effect on weight, balance, structural strength, reliability, operational characteristics, or other characteristics affecting the airworthiness of the product. All other changes are “major changes.” The major alteration form, FAA form 337, is included with the system, or can be downloaded from our website at <https://www.mindrumlasers.com/documents/>. Mindrum Precision assumes no responsibility for alterations not reported to the FAA.

Warranty information

Unless otherwise specified, Mindrum Precision Inc warrants the system for a period of twelve months from the date of delivery. This warranty, however, is subject to the following conditions:

1. Mindrum Precision shall be under no liability in respect to any defects in the equipment arising from any drawing, design or specification supplied or modification requested by the customer.
2. Mindrum Precision shall be under no liability in respect to any defects arising from normal wear and tear, willful damage, negligence, abnormal working conditions, failure to follow Mindrum Precision’s instructions (whether oral or in writing), misuse, alteration or repair of the equipment without Mindrum Precision’s approval.

Claims in respect to defective equipment must be directed to Mindrum Precision. The customer, pending direction from Mindrum Precision, must retain the equipment. Following authorized return of the equipment, which must be made by the customer on freight prepaid basis, Mindrum Precision will examine the equipment and if the claim is

justified, Mindrum Precision will repair the defective equipment or make replacement without charge. Mindrum Precision will have no further liability.